

SMK102 Front Panel Wiring Diagram

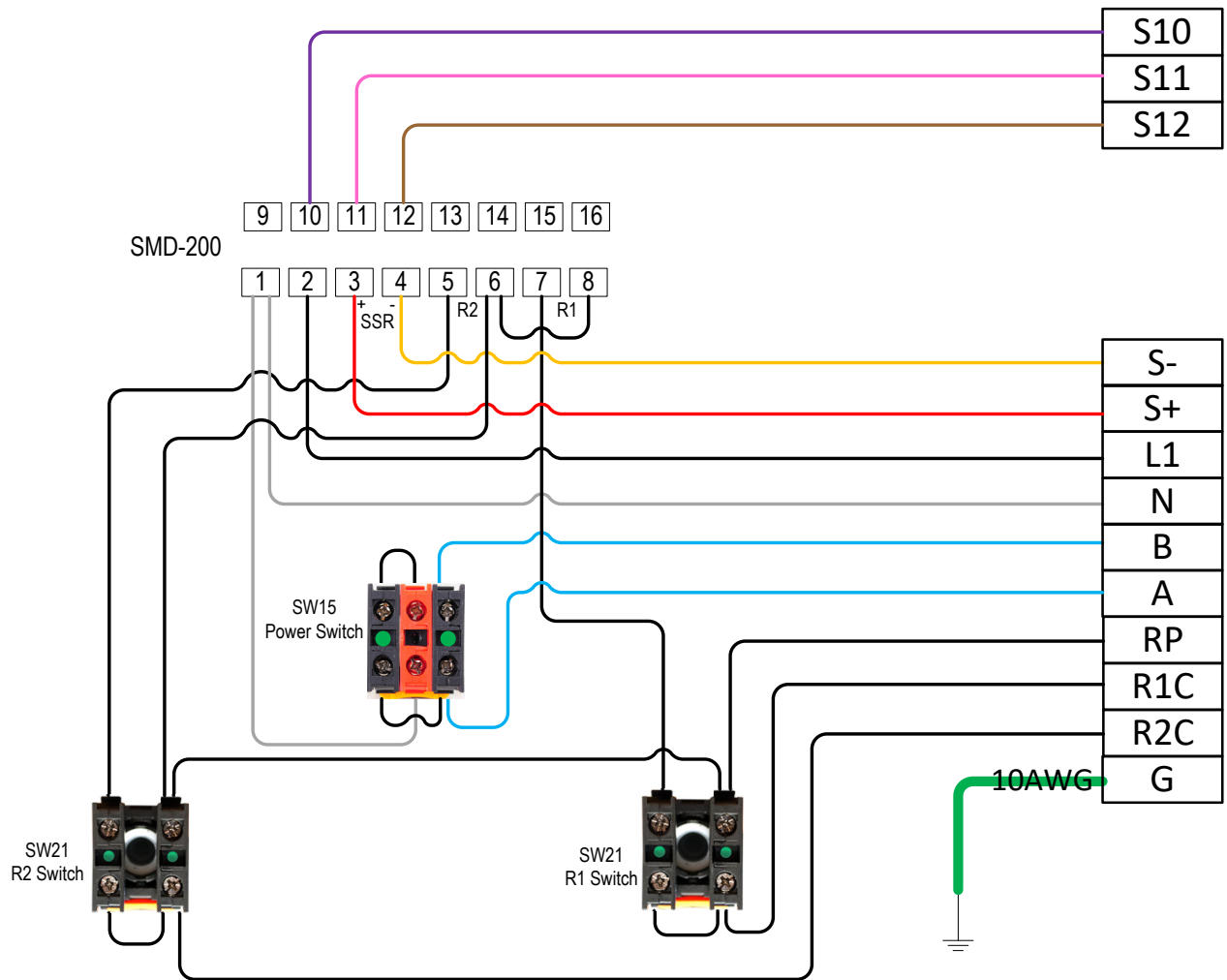

Legend	
—	Hot Control Line 22/24 AWG
—	Neutral Control Line 22/24 AWG
—	Grounding Wire 10 AWG
—	SSR Positive Control Wire 22/24 AWG
—	SSR Negative Control Wire 22/24 AWG
—	Sensor Connection Wire 22/24 AWG
—	Sensor Connection Wire 22/24 AWG
—	Sensor Connection Wire 22/24 AWG
—	Input Power Control Signal 22/24 AWG

SMK102 Power System Wiring Diagram

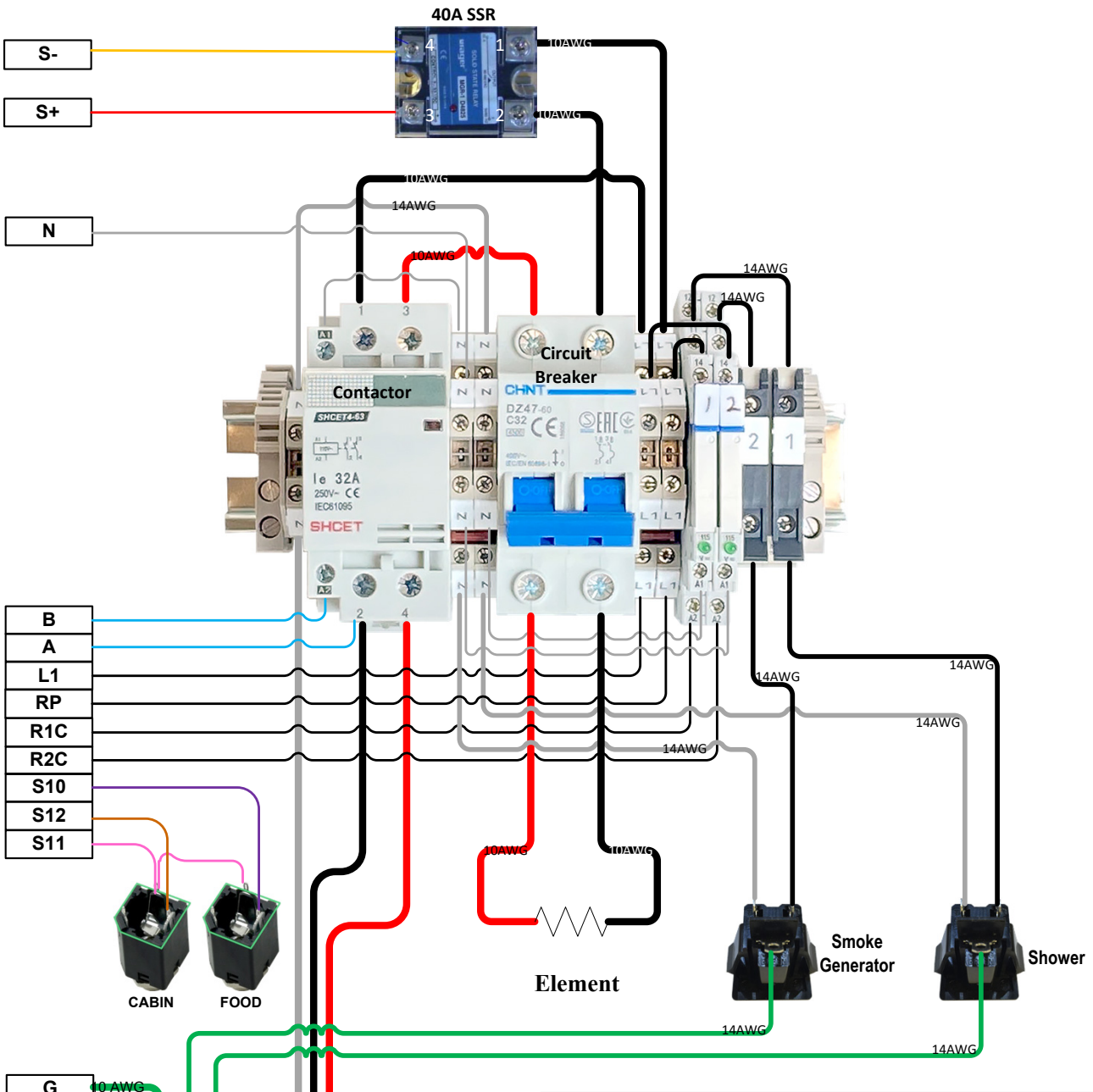

- Legend**
- L1 Hot Line (240V Power) 10 AWG
 - L2 Hot Line (240V Power) 10 AWG
 - Neutral Line (240V Power) 10 AWG
 - Ground Line (240V Power) 10 AWG
 - Neutral Control Line 14 AWG
 - Grounding Line 14 AWG
 - Hot Control Line 14 AWG
 - SSR Positive Line 22/24 AWG
 - SSR Negative Line 22/24 AWG
 - Sensor Connection Wire 22/24 AWG
 - Sensor Connection Wire 22/24 AWG
 - Sensor Connection Wire 22/24 AWG
 - Input Power Control Line 22/24 AWG

Copyright © 2020
www.auberins.com